

BLUE★STAR

**Windshield Repair System
Instruction Manual**



... The Professionals First Choice

Contents

Components and nomenclature	1
Introduction	2
Identifying types of breaks	2
About the Blue Star system	3
Cautions	3
Repair process	4

Helpful hints	11
Expected results	12
Remarks	12
Characteristics of Ultraviolet resin	12
Drilling	12
Drilling tips	12
Maintenance	13

Components and Nomenclature



Introduction

Every year thousands of windshields are damaged by flying rocks that affect the outer layer of the safety glass. Glass breaks can be filled with a transparent resin that protects the broken areas and substantially restores the visibility to the repaired area. This patented windshield repair system can repair many of these different types of breaks. Since all breaks are not alike, there will be a small percentage that cannot be repaired. This manual provides a step-by-step procedure for repairing the different type of breaks in windshields. In addition to becoming familiar with the procedure, it is important to understand the basic principals and different types of breaks that will assist you in performing the repair.

About auto safety glass

A. Safety Glass is a lamination of two plates of glass sandwiching a transparent binder. Breaks in a windshield usually only affect the outer plate of lamination and does not penetrate the entire windshield. Glass breaks can be filled with a transparent resin which protects the broken areas and substantially restores the visibility to the repair area.

B. Stone chips and bulls eye breaks in automobile windshields mar the visibility through the glass, but most often will not affect the useability of the glass. In many cases, such breaks can be repaired, eliminating expensive time consuming replacement of the entire glass.

C. When an object strikes the outer layer of glass with sufficient force, it causes a small hole on impact. This permits air to enter the damaged area. This air space creates a diffusion of light, resulting in an obstruction of vision.

D. The objective of this windshield repair system is to penetrate the glass surface through the pit of the break with a transparent liquid resin. The resin replaces the entrapped air, cures, and restores visibility, since it has the same index of refraction as the glass. The resin once cured also bonds the loose glass within the damaged area.

E. In most cases, the repair will not be totally invisible; there will always be traces of a repair. At the point of impact where the surface glass is missing, a slight imperfection will be visible. And in some cases, hairline remains of the radial cracks, called scars, may be visible when viewed at certain angles. Nevertheless, at least 90% of the optical diffusion will be eliminated, restoring transparency and rendering the area structurally sound. Further cracking will be prevented.

Types of Breaks.

All breaks are different, no two breaks are ever alike. They may appear to be alike, but each has unique characteristics. They do, however, have shapes that can be classified as being of a particular type. The five most common breaks are:

1. Bulls Eye



This break is cone shaped with the PIT (point of impact) at the surface, and the base at the inner liner.

2. Combination Break

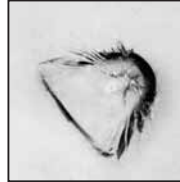

This break is a Bulls Eye type combined with radial cracks.

3. Daisy

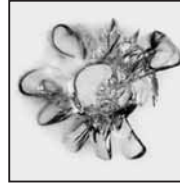

This break is non-symmetrical and consists of one or more cones with radial cracks having a flower type appearance.

4. Star



This break consists of a pit with radial cracks. The cracks do not penetrate through to the lamination. There is little or no air to displace, allowing a minimum of resin to penetrate. Results will vary

depending on the air passages.
Drilling a hole through the pit is recommended in order to get the resin to flow into the radial crack.

5. Crack

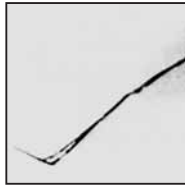

Cracks are difficult to repair requiring special tools and training.. Not recommended for repairing long cracks. Small cracks, 2" or smaller can be repaired by drilling a small hole(s) along the crack and using a thin based resin.

The Blue Star system

This is a professional windshield repair system and is designed to be easy to use. After you have made several repairs and become familiar with the process, you will find that repairs take very little time and produce excellent results.

The system has been designed to eliminate most of the guess work from the repair process. However, since all windshield breaks cannot be repaired, you must use your own judgement before attempting a repair.

Cautions

1. Always keep the resin bottle away from direct sunlight. Although the bottle itself is an adequate shield from ultraviolet rays, if a small portion is exposed, it may cause a chain reaction and cure within the bottle.
2. When making repairs outdoors use a sun screen to prevent the ultraviolet sun rays from curing the resin until the repair process is complete.

Note:

The sun's rays can also be present on cloudy days. Take care to insure the device is covered when performing repairs outdoors.

In the event the sun's UV rays cure the resin in the pedestal, the resin will not be able to remain liquid and will not be able to penetrate the break cavity.

3. Blue Star recommends the use of a UV curing lamp to cure the resin after the break is filled with the chemical resin.

When using an ultraviolet lamp, **do not look into the light**. Looking into an ultraviolet lamp can cause

sunburn to your eyes and skin. The light produces a high concentration of ultraviolet rays which should be avoided. Mere glances at the lamp are not dangerous.

4. **Never** attempt a repair while rain or other moisture is forming on the glass. The glass should be dry at all times.

Moisture can often be removed or reduced by compressed air. Hot air from an electric hair dryer or car defroster will be sufficient in most cases.

5. Always place the resin cap on the bottle tightly, to insure it does not leak. The resin is very thin-based and must be treated with care.

6. In the event the resin spills on the car surface, clean it up immediately, before it has a chance to cure (harden).

The Repair Process



1. Clean The Damaged Area

Use the Carbide tip probe carefully to probe the pit, freeing all the loose glass particles from the crushed cone, and to clean the hole of all the debris. Clear the loose glass from the break area. Clean the area surrounding the break with a dry cloth. Use glass cleaner if available. When using glass cleaner, spray the cleaner on the cloth, not into the damaged area.



2. Mount The Adhesive Seal To The Windshield

Peel the backing off one side of the adhesive seal. Line up the hole in the seal with the PIT of the break (pointing the tab upward). Press the seal to the glass. Run your fingers around the seal several times while pressing downward to insure a good bond.



3. Remove The Backing From The Seal

Peel the backing from the top side of the adhesive seal.



4. Remove The Backing From The Pedestal

Peel the backing from the bottom of the pedestal..



5. Mount The Pedestal To The Adhesive Base

Line up the pedestal with the adhesive seal making sure the TABS match up. Lightly press the pedestal to the seal. Run your fingers around the pedestal pressing downward to insure a good bond.



6a. Place UV Resin Into The Pedestal

Place the resin bottle's pouring spout into the pedestal opening and squeeze the bottle slowly until the resin level reaches the level shown in the diagram (6B).



6b. *The resin level is the joining point of the pedestal base and the pedestal stem. When making repairs outdoors, use a sun screen to prevent the ultraviolet sun rays from curing the resin until the repair process is complete.

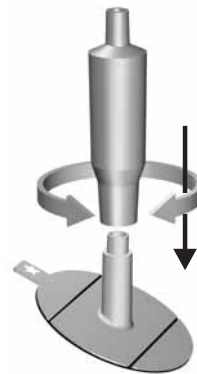

7. Connect The Flow Regulator To The Pedestal

Firmly press the flow regulator onto the pedestal with a twisting motion. (press fit connection)

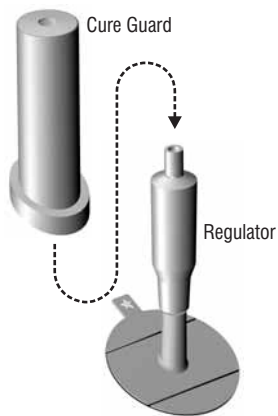

Note: Using a Cure Guard

When doing repairs outdoors, be sure to place the Cure Guard over the regulator first before making connection in step (8).



8. Connect The Hose To The Flow Regulator

Firmly press the hose slip fitting onto the flow regulator with a twisting motion. (press fit connection)

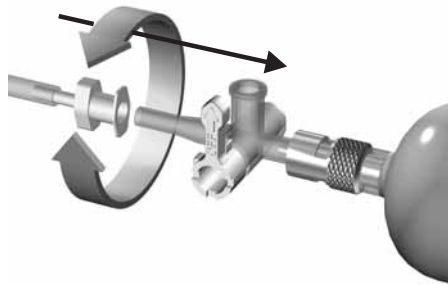

9. Connect The Hose To The Injector Valve

Connect the other end of the hose having lok fitting to the tip of the injector valve with a slight twisting motion. (press fit connection)

Note: If necessary, two hoses can be joined together to obtain a longer length.

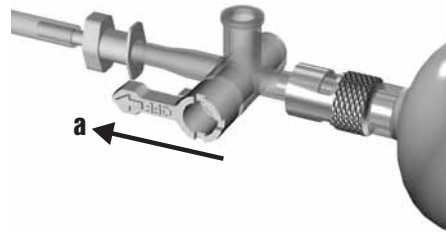

10a. Position The Plunger and Set The Valve Lever

Move the valve lever to the left.

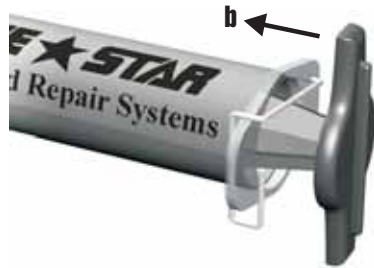

10b. Release the plunger from the spring clip and push the plunger completely into the injector barrel.

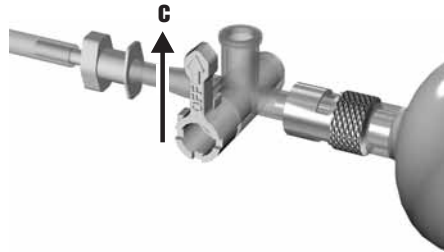

10c. With the plunger completely inserted, position the valve lever to the upright position.

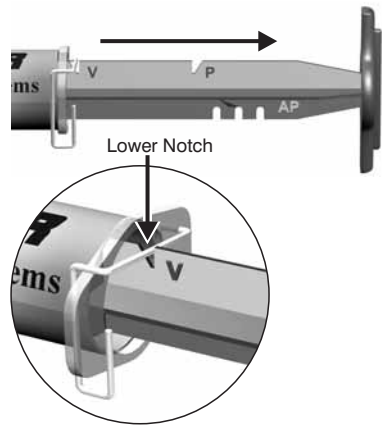

11. Lock The Plunger In The Vacuum Position

With the valve lever in the upright position, hold the injector barrel with one hand and pull the plunger **Slowly** upward with the other hand. Lock the plunger by engaging the lower notch in the plunger with the spring clip.

Note: Air is being removed during this step and bubbles can be seen entering the pedestal. Now go to step (12) to increase vacuum.

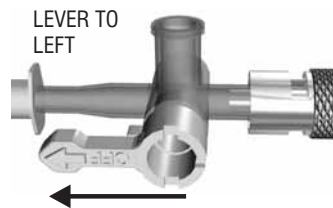

12a. Increase The Vacuum

Position the valve lever to the left and slide the plunger to the bottom of the injector barrel.

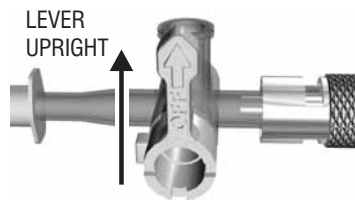

12b.

Return the valve lever to the upright, position and while pulling the plunger *slowly* upward, engage the spring clip in the lower notch.

Repeat steps **12A** and **12B** then, let sit for 5 to 10 minutes. Air is again being removed during this step and bubbles can be seen entering the pedestal.

1. LEVER TO LEFT

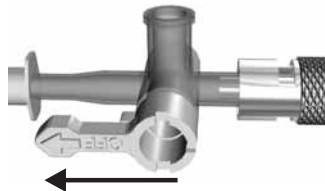

2. LEVER UPRIGHT

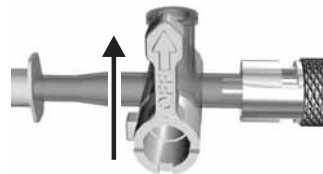

13. Fill The Injector Barrel With Air.

Move the valve lever to the left and then immediately position the valve lever to the upright position. The air that enters the injector barrel stops the vacuum action.

Note: Step 13 must be repeated 3 times for the vacuum to be fully dissipated.

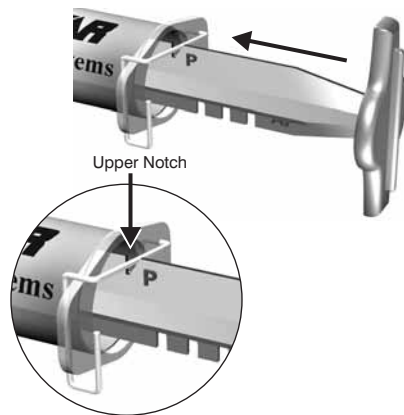

14. Move The Plunger To The Pressure Position

Insure that the valve lever is in the upright position. Holding the injector with one hand, rotate the plunger, releasing the spring clip from the lower notch.

Depress the plunger and engage the upper notch with the spring clip.
Remove hands from plunger and allow the device to sit for 10 minutes, or longer.

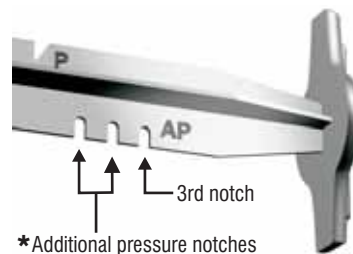

Note:

The resin is being forced under pressure into the break cavity. Since the resin flow is different for each break, some breaks will fill faster than others.

*Additional pressure can be obtained by using the additional pressure notches (**AP**) in the plunger stem. Caution should be used when applying additional pressure and the following considerations are suggested.

1. When applying additional pressure, run your fingers around the mounted pedestal to insure a good bond to compensate for the added pressure.
2. Use the third notch only when you have determined the repair is almost complete and the device is to be removed.

15. Review The Repair From Inside The Vehicle

A. If the break is completely filled with resin, without traces of air pockets, go to the next step (16).

B. If the break is partially filled having traces of air pockets, repeat steps (10a) thru (15), repeating the vacuum & pressure cycles.

Note:

All breaks are not alike and each have different air passages for the resin to flow into. Therefore some breaks might require repeated vacuum and pressure steps.

Monitoring Repairs From Inside The Vehicle

The hose allows for ease of operation as well as operating the injector barrel, while monitoring the repair process from inside the vehicle.

Damage prior to repair

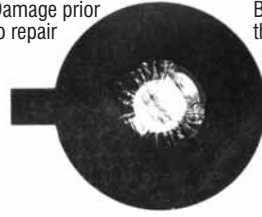

Break visible through seal

Incomplete repair

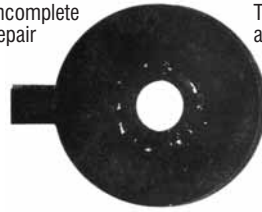

Traces of air pockets

Complete repair

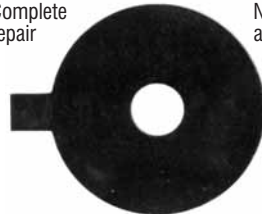

No traces of air pockets

16. Remove The Device From The Windshield

You can remove the device quickly and easily from the windshield by following these simple steps.

1. Rotate the plunger, releasing it from the spring clip and allowing the plunger to move freely. (This step relieves the pressure in the injector barrel)
2. Separate the Flow Regulator from the pedestal by twisting and pulling upward on the regulator connection.
3. Loosen the outer edges of the pedestal with a safety razor.
4. Remove the pedestal by holding the tab and pulling downward. The grooves in the pedestal allow it to bend for easy removal. **Do not force.**
5. Wipe excess resin with a clean cloth. Continue using the safety razor until the pedestal is removed. Place a rag below the pedestal when removing to absorb the excess resin from the pedestal. The pedestal can be cleaned and re-used with a new seal or discarded.



17a. UV Curing Prep

Place a drop of resin in the Pit

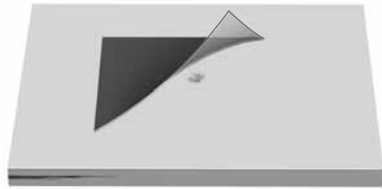

17b. Place a strip of mylar or cellophane over the repaired break area.

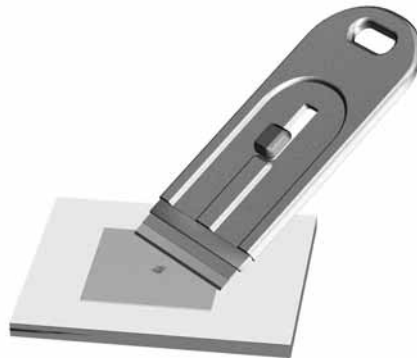

17c. Take a razor blade and with an upward motion, smooth out the mylar. The upward motion will insure that the resin fills the pit and is held in place with the mylar until the curing procedure is completed.

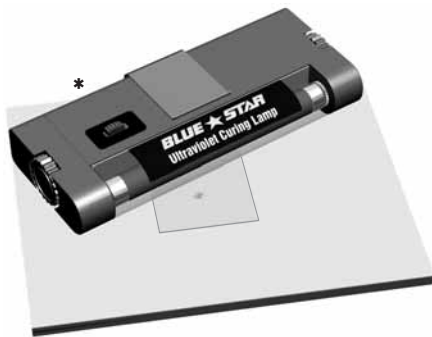

18a. Curing with a UV Lamp

Place the ultraviolet curing lamp over the repaired area and turn on the lamp for 5 minutes. The UV resin will cure (harden).

Note: The center of the bulb provides the highest UV intensity.

*If using a battery type UV lamp, it may take longer to cure if the batteries do not have a satisfactory charge.

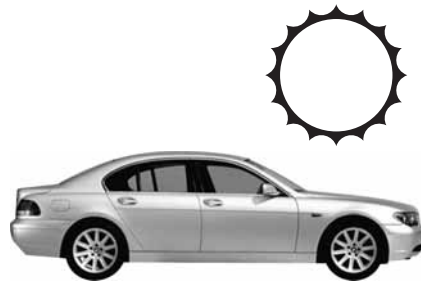

18b. Curing with the sun

If a UV curing lamp is not used, place the vehicle in the sun to cure the resin. The curing time will vary depending on the intensity of the sun.

The resin will remain liquid until a sufficient UV light source is applied.



19. Finish

Remove the mylar from the repaired area. With a razor blade, scrape the excess resin from the windshield. Scrape the resin in one direction only.

Polish the repaired area with the plastic polish provided.

Helpful Hints

It is important to clean out the break PIT using the carbide tip probe. There are some breaks that do not have a large enough pit for the resin to penetrate.

The probe can be used to enlarge the pit simply by probing with the probe. The probe can scratch the glass, so be careful when using it and avoid any unnecessary scratches.

The product design has taken most of the judgement out of the repair process. However, since all breaks are not repairable, good judgement is required in determining which breaks can and cannot be repaired.

Once the seal is placed on the windshield, it is helpful to view the break from inside of the vehicle to establish a visual reference. The reference allows you to monitor the progress of the repair while the repair is taking place.

Since the process normally is performed unattended once it is set up, you can change the specified time intervals and coordinate these time intervals with other duties. However, if you are performing the repair within a specified time span, the specified intervals are recommended.

Should you remove the pedestal and find that it was removed too soon, another pedestal can be mounted and the repair started over. Since the resin is still liquid, the air passages are not blocked. Be sure to clean the glass prior to mounting another seal.

Repairs to the windshield which are in the direct vision of the driver should be avoided.

Expected Results

If you've followed the step-by-step instructions, you can expect to achieve the following results:

- A.** The outline of the pit will be visible and it will depend upon the original size.
- B.** Hairline cracks may still be visible, and their visibility will depend upon the type of break being repaired. Combination breaks will in most cases, have hairline cracks which are dependent upon the severity of the breaks.
- C.** In cases where the resin is not able to penetrate the break, slight air pockets within the break may be visible.
- D.** The repair process accomplishes two things.
 - 1.** It bonds the loose glass below the surface, and prevents the break from developing into a crack.
 - 2.** It restores the visibility. Once open air cavities are filled with resin, the distortion is removed.

Remarks

Please note that the process is a repair, not a new glass. Cosmetic (visual) results of a repair attempt will range from perfect or invisible to no obvious improvement.

Excellent repairs can be made simply and quickly but there are some basic limitations to consider.

- A.** To avoid possible glare distraction, repairs should not be attempted in the drivers critical vision area.
- B.** Old breaks with relatively large pit areas (point of impact with glass missing) usually collect contamination from moisture. This moisture may be wind driven or washed into the break by the wiper blade.
- C.** There are some breaks that do not have a large enough pit (point of impact surface damage) to allow resin to penetrate the break, resulting in little or no improvement.

In these cases, use of the carbide tip probe to open up the pit is required, and/or drilling a small hole may be necessary, in order to open up an air passage for the resin to penetrate the break cavity.

Characteristics of Ultraviolet Resin

- A.** The UV resin cures through the absence of air and by exposure to ultraviolet rays. It will cure merely by being exposed to ultraviolet rays, but it does take longer, and the surface will remain tacky. The absence of air alone will not cure it.
- B.** The normal curing cycle with the two conditions present is approximately five minutes in either direct sunlight or under the UV lamp, and 20 to 30 minutes on a cloudy day.
- C.** The resin is not affected by hot or cold weather, but it is recommended that it be kept out of freezing temperatures.

Remember: The special UV resin will always remain liquid until a UV light source is applied.

Drilling

Although the majority of breaks will not require drilling, you should be familiar with the method in the event you want to consider doing it.

Normally, drilling is required when the impact pit is

quite small, the radial cracks immediately adjacent to the impact pit are quite small, and the radial cracks immediately adjacent to the impact pit are very thin. Resin often enters such cracks very slowly or not at all.

Drilling can also be used to stop a stress crack from travelling. Stress cracks that start at the edge of the windshield can be prevented from spreading and filled with a resin, provided the crack is small.

Drilling Tips

- 1.** Use a fine carbide drill bit.
- 2.** Use a fine Diamond or carbide tip probe to mark a spot on the glass where the drilling is to take place.
- 3.** Keep the drill motor running at all times while the drill bit is in the hole being drilled. Stop the motor only after you withdraw the drill bit to avoid any stress on the glass.
- 4.** Drill at short intervals to avoid excess heat.
- 5.** Do not drill to the inner liner.
- 6.** Extreme care must be taken when drilling glass. Excess stress can cause cracks.

Maintenance

The injector barrel is a powerful vacuum and pressure pump and is frequently used on a daily basis. A routine schedule of maintenance will provide trouble free operation and extend the life of the injector barrel. It is recommended that these maintenance procedures be performed after every 15 to 20 repairs, or if the plunger assembly stops moving freely.

1. Remove plunger assembly by depressing the spring clip on the barrel and pulling out the plunger.
2. Clean inside of injector barrel with a soft cloth moistened with Isopropyl or rubbing alcohol. Allow to dry for a minimum of five minutes.
3. Remove rubber seal from plunger and thoroughly clean with soft cloth and alcohol. Allow to dry for five minutes.
4. Replace rubber seal on plunger and lubricate with a general purpose silicone spray or equivalent.
5. Re-install plunger assembly by depressing spring clip while pushing plunger into injector barrel. Work plunger assembly through it's normal

ranges of motion a few times to insure proper distribution of lubricant inside injector barrel.

BLUE STAR

Windshield Repair System Instruction Manual

Warranty

Blue Star Products, Inc. warrants all equipment and chemical to be free from workmanship defects when used under normal usage of such as prescribed in the Instruction Booklet for a period of ninety (90) days from the date of purchase. Such equipment or chemical, within the period of the warranty, shall be replaced or repaired at manufacturer option without charge to the consumer only when it has been determined in good faith such defect was due to materials and/or workmanship.

Manufactured by:
Blue Star Products, Inc.
Patented, US, Canada and Foreign Countries.



Patented, United States, Canada and Foreign Countries

©Blue Star Products, Inc. 2007

Blue Star Products, Inc. 355 Marcus Blvd. Hauppauge, NY 11788
Tel: 631.231.5222 Web site: www.bluestar-products.com